

SIDE VIEW

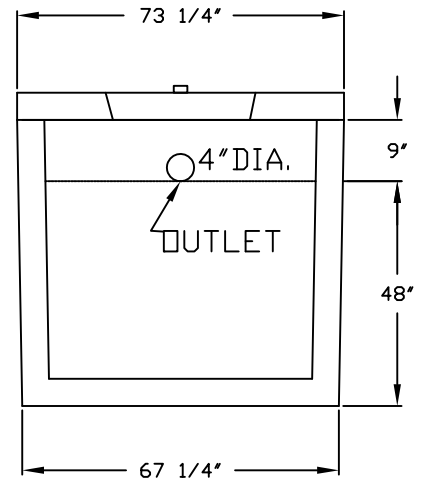

END VIEW

TANK: CATEGORY 3. 3" 1650 GALLON 2 COMPARTMENT TANK REINFORCED WITH FIBRILLATED POLYPROPYLENE FIBER. 3" WALLS AND 4" BOTTOM. INLET AND OUTLET RESILIENT CONNECTORS PER ASTM-923-98. CONNECTORS MUST BE USED WITH APPROVED CLAMP. CONNECTOR WILL ACCEPT 4" PVC PIPE.

**LIDS: 4" LID WITH 1-22" ROUND MANHOLE COVER AT EACH END OF TANK
8" LID WITH 1-22" ROUND MANHOLE COVER AT EACH END OF TANK
BOTH LIDS ARE REINFORCED WITH GRADE 60 REBAR.**

TANK & LIDS: 4000 PSI CONCRETE AT 28 DAYS

IMPRINTED ON INLET END OF TANK:

LEGEND: FSI 1650 STATE APPROVAL: 01-011-24D-C3

**WEIGHTS: TANK ONLY 9,080
 TANK W/ 4" LID 12,960
 TANK W/ 8" LID 16,840**

THIS SEWAGE TREATMENT RECEPTACLE HAS BEEN DESIGNED, CONSTRUCTED AND STRUCTURALLY TESTED IN ACCORDANCE WITH CHAPTER 64E-6.013, FLORIDA ADMINISTRATIVE CODE, (FAC) DATED MARCH 22, 2000.

DRAWING NOT TO SCALE

FLORIDA SEPTIC, INC.

P.O. BOX 545

HAWTHORNE, FLORIDA 32640

(800) 940-8265

MODEL:

3" 1650 GAL. TANK

**REVISED:
05/01/2011**

**APPROVAL DATE:
07/30/2001**