

SIDE VIEW

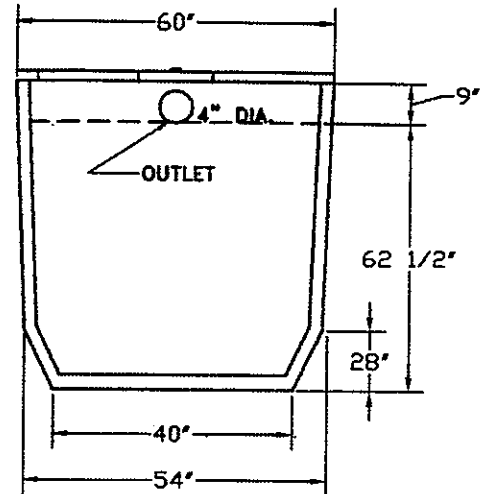

END VIEW

TANK: CATEGORY 3. 3" 1350 GALLON 2 COMPARTMENT TANK REINFORCED WITH FIBRILLATED POLYPROPYLENE FIBER. 3" WALLS AND 3" BOTTOM. INLET AND OUTLET RESILIENT CONNECTORS PER ASTM-923-98. CONNECTORS MUST BE USED WITH APPROVED CLAMP. CONNECTOR WILL ACCEPT 4" PVC PIPE.

**LIDS: 4" LID WITH 1-22" ROUND MANHOLE COVER AT EACH END OF TANK
8" LID WITH 1-22" ROUND MANHOLE COVER AT EACH END OF TANK
BOTH LID ARE REINFORCED WITH GRADE 60 REBAR.**

TANK & LIDS: 4000 PSI CONCRETE AT 28 DAYS

**IMPRINTED ON INLET END OF TANK:
LEGEND: FSI 1350 STATE APPROVAL NUMBER: 01-011-16D-C3**

**WEIGHTS: TANK ONLY 8,036
TANK & 4" LID 10,588
TANK & 8" LID 13,138**

THIS SEWAGE TREATMENT RECEPTACLE HAS BEEN DESIGNED, CONSTRUCTED AND STRUCTURALLY TESTED IN ACCORDANCE WITH CHAPTER 64E-6.013, FLORIDA ADMINISTRATIVE CODE, (FAC) DATED MARCH 22, 2000

DRAWING NOT TO SCALE

FLORIDA SEPTIC, INC.

**P.O. BOX 545
HAWTHORNE, FLORIDA 32640
(800) 940-8265**

**MODEL:
3" 1350 GAL. TANK**

**REVISED:
12/27/01**

**APPROVAL DATE:
05/31/01**